

San-Flo

Floor Drain

**Suitable underfloor
drain systems in :-**

- ◆ **Epoxy Floors**
- ◆ **Concrete Floors**
- ◆ **Tiled Floors**

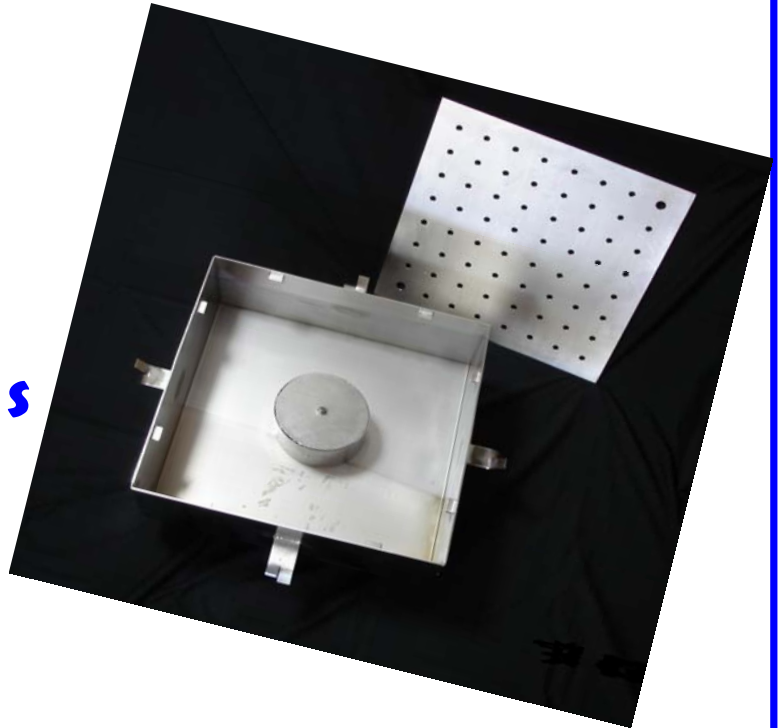

- ✓ **San-Flo floor drains are available in S30400 and S31600 stainless steel.**
- ✓ **Drains have a removable top plate and are able to withstand heavy forklift traffic.**
- ✓ **High capacity prevents hold-up waste stream.**
- ✓ **Available with 100 diameter horizontal or vertical drain.**
- ✓ **San-Flo floor drains are designed and manufactured in Australia to conform to Australian Dairy Standards.**
- ✓ **Suitable for all food manufacturing premises.**
- ✓ **Can be cleaned and sanitized from floor level.**
- ✓ **Positive water seal to isolate drain and odours.**



Food Process Engineering Pty Ltd

P.O. Box 2063, Research
Victoria, 3095 Australia
Telephone : 61-3 9433 9600
Facsimile : 61-3 9433 9666
Email : info@foodpro.com.au
Website: www.foodpro.com.au



FEATURES

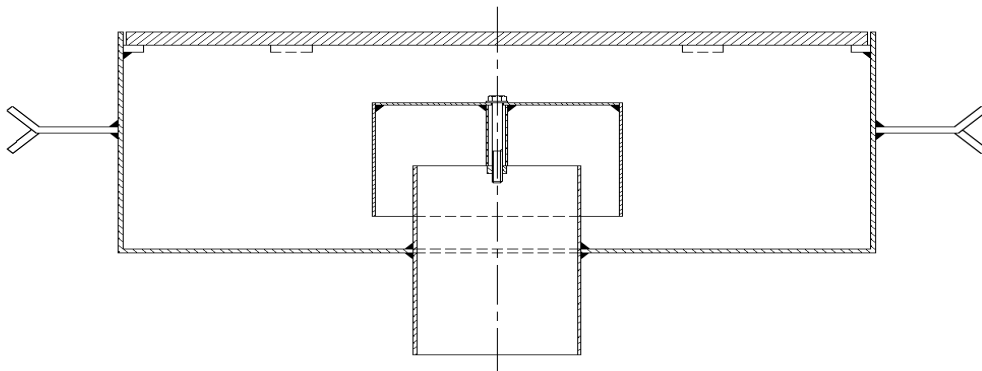
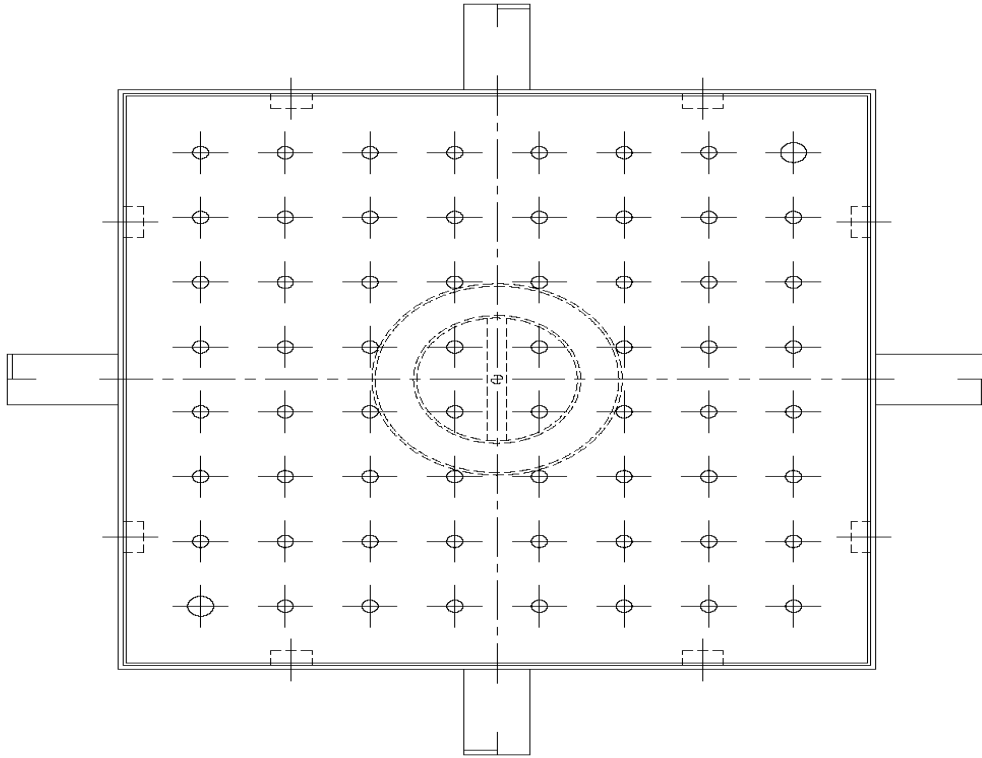

Standard size :
L 450 x W 450 x D 175 mm

Available in alternate sizes
upon request.

